

RSL 2" SINGLE FILTER

Applications

The RSL SINGLE FILTER disk filtering station is composed of a Rotodisk, a filter equipped with a particular mechanical and hydraulic system that allows its automatic backwashing. Assembled individually with two, three-way hydraulic valves, an auxiliary disk filter and a controller for automatic management of the wash cycles (timed and pressure differential). The RSL station is mainly used as primary filtration of water particularly weighted with suspended particles, or as secondary filtration downstream of the quartzite filters or sand separators.

Materials

- Filter: polyamide reinforced with fibre glass
- Collectors: HDPE
- Hydraulic valves: plastic or cast iron
- Victaulic fittings: cast iron
- Filtering element: polypropylene disks
- Accessories: polypropylene

Characteristics

- Maximum working pressure: 10 bar at 20°
- Standard filtration grade: 120 mesh (filtration available: 80, 120, 150, 200 mesh)
- Threaded connections: victaulic (up to 4"), flanged (over 4")
- The filtering station is supplied with air discharge valves, fittings for backwash water discharge and an automation kit
- Resists acids and fertilisers commonly used in agriculture



Load loss*

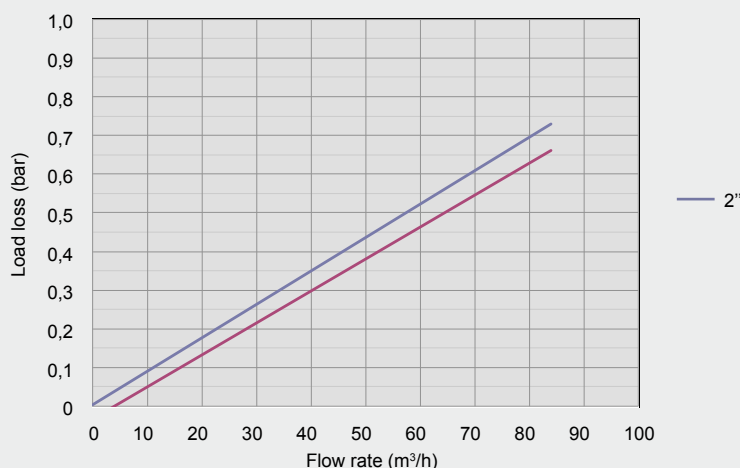

*Testing for load loss was carried out with clean water.

RSL 2" SINGLE FILTER

Technical data

No. filters	Pricelist ref.	Rec. max. flow rate (m ³ /h)	Ø collector	Connections	Collector	Discharge
1	IFRSL201GBGUL	24	2"	threaded	epoxy paint. steel	2" - 63mm

Dimensions

Ø (inches - DN)	L (mm)	L1 (mm)	H (mm)	H1 (mm)	H2 (mm)	H3 (mm)
2"	660	690	1700	100	770	350

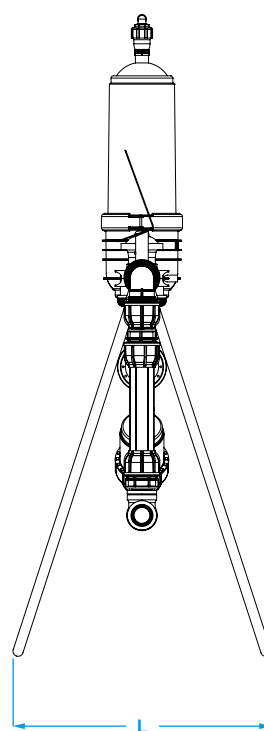
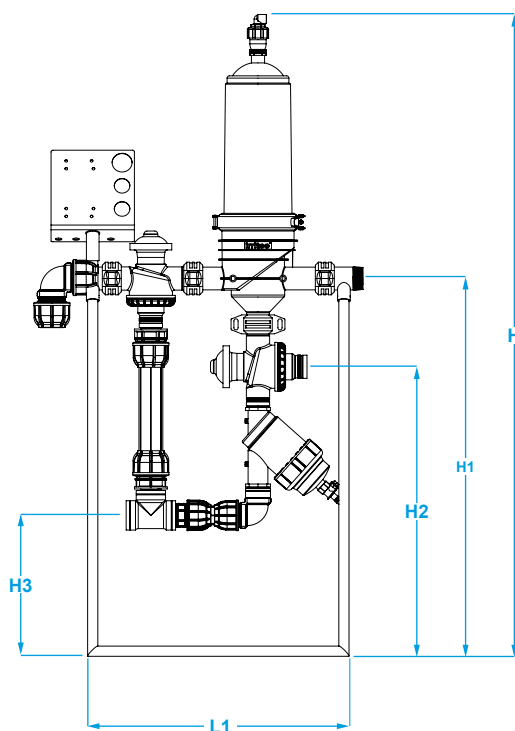

Components

Number	Description
1	female elbow ø 63x2"
2	victaulic fitting 2"
3	hydraulic valve 90° 2" 3-way
4	male fitting ø 63x2"
5	TAF filter 2"
6	Tee 2" threaded
7	male fitting ø 50x2"
8	HDPE pipe PN10 ø 50
9	female elbow ø 50x2"
10	YFV disk filter 2"
11	3/4" discharge valve
12	air release valve
13	HDPE pipe PN10 ø 63
14	cap 2"

